

PXV

Pulse-type electronic expansion valve

rel. 06/21

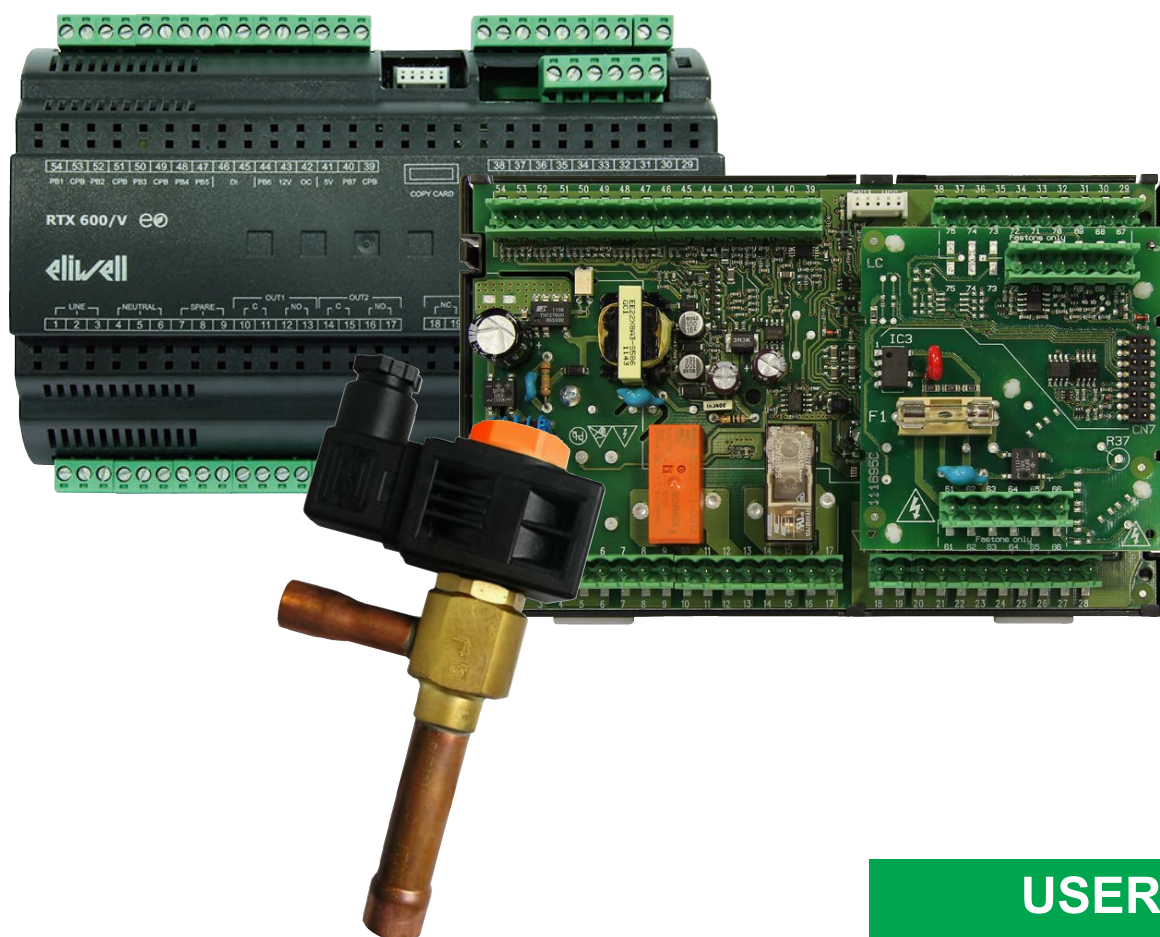

**USER
MANUAL**

Legal Information

The Schneider Electric brand and any trademarks of Schneider Electric SE and its subsidiaries referred to in this guide are the property of Schneider Electric SE or its subsidiaries. All other brands may be trademarks of their respective owners.

This guide and its content are protected under applicable copyright laws and furnished for informational use only. No part of this guide may be reproduced or transmitted in any form or by any means (electronic, mechanical, photocopying, recording, or otherwise), for any purpose, without the prior written permission of Schneider Electric.

Schneider Electric does not grant any right or license for commercial use of the guide or its content, except for a non-exclusive and personal license to consult it on an "as is" basis. Schneider Electric products and equipment should be installed, operated, serviced, and maintained only by qualified personnel.

As standards, specifications, and designs change from time to time, information contained in this guide may be subject to change without notice.

To the extent permitted by applicable law, no responsibility or liability is assumed by Schneider Electric and its subsidiaries for any errors or omissions in the informational content of this material or consequences arising out of or resulting from the use of the information contained herein.

As part of a group of responsible, inclusive companies, we are updating our communications that contain non-inclusive terminology. Until we complete this process, however, our content may still contain standardized industry terms that may be deemed inappropriate by our customers.

© 2021 Eliwell. All rights reserved.

CONTENTS



	SAFETY INFORMATION	4
	INFORMATION ABOUT.....	6
CHAPTER 1.	INTRODUCTION.....	10
	1.1. DESCRIPTION	10
	1.2. BOX CONTENTS.....	11
CHAPTER 2.	MECHANICAL INSTALLATION	12
	2.1. BEFORE STARTING	12
	2.2. DISCONNECTION FROM THE POWER SUPPLY.....	12
	2.3. OPERATING ENVIRONMENT.....	13
	2.4. COMMENTS CONCERNING INSTALLATION	13
	2.5. PXV INSTALLATION.....	14
	2.6. PXV SERVICING	17
	2.7. COIL + CONNECTOR.....	19
CHAPTER 3.	ELECTRICAL CONNECTIONS.....	21
	3.1. WIRING PRACTICES	21
	3.1.1. Specific considerations for handling.....	21
CHAPTER 4.	TECHNICAL DATA	22
	4.1. VALVE TECHNICAL DATA.....	22
	4.2. COIL TECHNICAL DATA.....	23
	4.3. APPROVALS.....	24
	4.4. MECHANICAL CHARACTERISTICS.....	25
CHAPTER 5.	SPARE PART KIT and O-Ring SET	28
	5.1. SILENT SPARE PART KIT AND O-RING SET TABLE	28
	5.2. SPARE PART KIT AND O-RING SET FITTING	29
CHAPTER 6.	GENERAL VALVE CHARACTERISTICS TABLE	33
	6.1. GENERAL VALVE BODY CHARACTERISTICS TABLE.....	33
CHAPTER 7.	VALVE SELECTION.....	38

SAFETY INFORMATION



Important information

Read these instructions carefully and visually inspect the equipment to familiarize yourself with the device before attempting to install it, put it into operation, review it or service it.

The following warning messages may appear anywhere in this documentation or on the equipment to warn of potential dangers or to call attention to information that can clarify or simplify a procedure.



The addition of this symbol to a danger warning label indicates the existence of an electrical hazard that could result in personal injury should the user fail to follow the instructions.



This is the safety warning symbol.

It is used to warn the user of the potential dangers of personal injury. Observe all the safety warnings that follow this symbol to avoid the risk of serious injury or death.

DANGER

DANGER indicates a dangerous situation which, if not avoided, **will result in** death or serious injury.

WARNING

WARNING indicates a dangerous situation which, if not avoided, **could result in** death or serious injury.

CAUTION

CAUTION indicates a potentially dangerous situation which, if not avoided, **could result in** minor or moderate injury.

NOTICE

NOTICE used in reference to procedures not associated with physical injuries.

NOTE

Electrical equipment must only be installed, used and repaired by qualified technicians.

Neither Eliwell nor Schneider Electric accept any liability for any consequences arising from the use of this material. An authorized person is someone in possession of the skills and knowledge applicable to the structure, to the operation of the electrical equipment and to its installation, and who has received safety training in order to recognize and avoid the risks involved.

Personnel qualification

Only personnel with suitable training and an in-depth knowledge and understanding of the contents of this manual and any other documentation relevant to the product are authorized to work on and with this product. Plus, they must be familiar with the personal safety laws, provisions and regulations which must be observed during system planning and implementation.

Permitted use

The valve and coil assembly must be installed and used in accordance with the provided instructions and in particular, in normal conditions, dangerous energized parts must not be accessible. The valve and coil assembly must be suitably protected against water, dust, overpressure and overtemperature based on the application and must also be accessible only with the use a tool.

The valve and coil assembly is suited for integration into a system for large-scale distribution and/or similar for refrigeration and climate control purposes and has been checked on the basis of the harmonized European standards of reference.

Prohibited use

Any use other than what is permitted is in fact prohibited.

Liability and residual risks

The liability of Eliwell and Schneider Electric is limited to the correct and professional use of the product according to the directives referred to herein and in the other supporting documents, and does not cover any damage (including but not limited to) the following causes:

- unspecified installation/use and, in particular, in contravention of the safety requirements of the legislation in force in the country of installation and/or specified in this document;
- use on equipment which does not provide adequate protection against electrocution, water, dust, overpressure and overtemperature in the actual installation conditions;
- use on devices which allow access to dangerous parts without the aid of a keyed or tooled locking mechanism;
- product tampering and/or alteration;
- installation/use on equipment that does not comply with the regulations in force in the country of installation.

Disposal

The equipment (or product) must be subjected to separated waste disposal in compliance with local legislation regarding waste disposal.

Production date

The production date is shown on the device label, indicating the week and year of production (WW-YY).

INFORMATION ABOUT...



Scope of the document

This document describes the pulse electronic expansion valves (EEVs) and the relevant accessories; it also provides information regarding installation and wiring.

Use this document to:

- Install and use **PXV** valves
- Familiarize yourself with **PXV** valve functions

NOTE: Read this document and all related documents carefully before installing, operating or servicing the device.

Note regarding validity

This document applies to **PXV** valves.

The technical characteristics of the devices described in this manual are also available online, through the Eliwell website www.eliwell.com.

The characteristics illustrated in this manual should be identical to those which can be found online. In line with our policy of constant improvement, we may later revise the content to improve its clarity and accuracy. If you notice any discrepancies between the manual and the information available online, use the latter as your point of reference.

Related documents

Document type	Reference document code	Document title
User manual	9MA00290	9MA00290 MAN EEV PXV IT
	9MA10290	9MA10290 MAN EEV PXV EN
	9MA20290	9MA20290 MAN EEV PXV FR
	9MA30290	9MA30290 MAN EEV PXV ES
	9MA50290	9MA50290 MAN EEV PXV DE
	9MAA0290	9MAA0290 MAN EEV PXV RU
	9MAF0290	9MAF0290 MAN EEV PXV PL
Technical Sheet	9IS54637	9IS54637 IS EEV PXV EN-IT-RU

You can download these technical publications and other technical information from our website at:

www.eliwell.com

Product related information

DANGER

RISK OF ELECTRIC SHOCK, EXPLOSION OR ARC FLASH

- Disconnect all power from all equipment including connected devices prior to removing any covers or doors, or installing or removing any accessories, hardware, cables or wires.
- Always use a properly rated voltage sensing device to confirm the power is off where and when indicated.
- Before restoring the power supply, replace and secure all covers, hardware components and cables.
- For all the devices requiring it, make sure there is an effective ground connection.
- Use only the specified voltage when operating this equipment and any associated products.
- Do not connect the device directly to the line voltage, unless expressly indicated.

Failure to follow these instructions will result in death or serious injury.

WARNING

UNINTENDED EQUIPMENT OPERATION

- Make sure the electrical connections are perfectly intact. If you notice any unusual warping, do not proceed with installation.
- Only proceed with the electrical connections once installation in the system has been completed.
- Power line and control circuits must be electrically connected in compliance with local and national regulatory requirements for the rated current and voltage of the particular equipment.
- Do not use the device in equipment or machines with safety functions.
- Tighten the orange locknut and the standard locknut in compliance with the technical specifications for torque values.
- Remove and repair the valve in accordance with the requirements specified by current standards ⁽¹⁾.

Failure to follow these instructions can result in death, serious injury, or equipment damage.

⁽¹⁾ The equipment must only be installed, repaired and upgraded by expert technicians in possession of the necessary qualifications and authorizations as specified by current regulations in the relevant regions. In countries within the European Union these technicians must possess refrigeration technician certification in compliance with F-GAS directive (Italian Presidential Decree N°43 dated 27/10/2012, ex EC 303/2008), in accordance with the methods indicated in the product documentation. The abovementioned personnel are also required to assume responsibility for using genuine spare parts officially supplied by Eliwell.

Flammable refrigerant gases

PXVN models

The use of flammable refrigerant gases depends on many factors, including current standards set out by national regulations or by relevant certifying authorities.

The devices and relative accessories described in the documentation supplied with the product use components and - to be more specific - electromechanical relays tested in accordance with standard IEC 60079-15 and classified as nC components (non-sparking electrical devices 'n'). This ensures conformity with Annex BB EN/IEC 60335-2-89.

Conformity with Annex BB EN/IEC 60335-2-89 is considered sufficient - and therefore suitable - for commercial refrigeration and HVAC systems using flammable refrigerant gases such as R290. Nevertheless, there may be other limitations, devices, locations and/or machine types (refrigerators, automatic distributors and dispensers, bottle coolers, ice machines, chiller cabinets for self-service facilities, etc.) involved, leading to the application of further restrictions and/or obligations.

The use and application of the information contained in this document requires experience in the design and parameterization/programming of control systems for refrigeration and HVAC systems. Only you, i.e. the original equipment producers, installers or users, can be aware of the conditions and factors present, in addition to the applicable regulations during the planning, installation and setup, operation and maintenance of the machine, or the related processes. Therefore, only you can decide on the suitability of the automation and the associated equipment, and the resulting safety measures and interlock devices that can be applied effectively and adequately in the locations in which the relevant equipment is to be commissioned. When choosing the automation and control equipment - and any other related equipment or software - for a particular application, you must also take account of all the standards set out by applicable national legislation or by the relevant certifying authorities.

When using flammable refrigerant gases, at the end of the installation process for this controller and related equipment you must make sure the machine conforms to current standards and regulations. Although all the declarations and information contained herein are to be considered accurate and reliable, they are not covered by warranty. The information provided herein does not absolve the user from responsibility in terms of performing their own tests and certifications of conformity to all applicable regulations.

 WARNING
REGULATORY INCOMPATIBILITY Make sure that all equipment used and systems designed comply with all applicable local, regional and national laws. Failure to follow these instructions can result in death, serious injury, or equipment damage.

PXVB, PXVE models

This equipment is designed to operate in non-hazardous locations and where applications which generate (or could potentially generate) hazardous environments have been isolated.

DANGER

POTENTIAL FOR EXPLOSION

- Install and use this device in non-hazardous locations only.
- Do not install or use this equipment in applications which could generate hazardous atmospheres, such as applications which use flammable refrigerants.

Failure to follow these instructions will result in death or serious injury.

For information regarding the use of control equipment in applications capable of generating hazardous materials, please contact the relevant national regulatory bodies or certifying authorities.

CHAPTER 1

INTRODUCTION

1.1. DESCRIPTION

Application

The PXV solenoid expansion valve regulates the flow of liquid refrigerant to the evaporator by modulating the opening time of its obturator, allowing a broad power variation interval. High-precision and reliable refrigerant flow regulation makes it possible to increase the efficiency of the entire system.

“Silent” models that operate at low noise levels are available.

Various interchangeable power orifices, nominally rated from 1 kW to 24 kW (non-silent models), are available.

The PXV valve can be controlled by the following Eliwell devices:

RTX600/V(DOMINO), RTN600/V(DOMINO) and V800. It is typically used in refrigeration systems, especially the chiller cabinets utilized by large supermarket chains.

In particular:

Commercial refrigeration

- hypermarkets, supermarkets, food stores
- hotels, restaurants

Industrial refrigeration

- food processing and distribution procedures

Residential climate control

- air conditioners, heat pumps for residential use featuring compressors with inverter

The PXV valve can be used as an evaporation pressure regulator in refrigeration systems with one or more evaporators and a hot gas by-pass valve, for capacity control.

Characteristics

These are a new generation of devices with main functions as follows:

- Evaporator overheating control via a built-in driver for pulse-type (EEV) valves
- New models for refrigerants R290, R600, R600a, R744 (CO₂)
- Capacity up to 24 kW with R410 (non-silent models)
- Optimizes the injection of liquid refrigerant into the evaporator, increasing its efficiency
- 230 Vac and 24 Vac available
- Improves overheating control when operating conditions change

In this manual, the photographs and diagrams are provided to illustrate the **PXV** device (and other Eliwell devices) and are purely illustrative. The corresponding dimensions and proportions may not correspond to actual dimensions in terms of life-size or scale. Furthermore, all the wiring or electrical diagrams should be considered as simplified representations which do not exactly correspond to the reality.

NOTE. We recommend you refer to the manuals for the relevant Eliwell controllers when performing PXV valve electrical connections.

Operation

The PXV valve is a throttling device that receives liquid from the condenser and introduces it into the evaporator, performing the necessary pressure jump on the expansion nozzle.

It is an ON / OFF valve that needs to be controlled according to the pulse width modulation criterion, known as “**Pulse Width Modulation**”, and lends itself to being controlled by rather simple electronics. According to this principle, once a reference period T has been set for the regulator, the refrigerant flow rate QT required by the evaporator in that period is supplied by the valve in a time interval t shorter than the period T , during which the maximum flow rate passes through (ON phase). During the remaining time interval $T - t$ the valve remains closed (OFF phase). Therefore, for efficient regulation, the PXV valve must be sized so that, under the most demanding conditions, it can provide an amount of refrigerant that is sufficient to tackle the request; in these extreme conditions the valve will remain open for the entire period T . Using an RTX/RTN 600 electronic regulator increases the precision of the amount of refrigerant used, resulting in improved efficiency over time (thereby significantly reducing machine management costs) and a quicker response to variations in evaporator load.

Coils and connectors

The coils that can be used for this valve are listed in the Coils and connectors section summarizing the main features of the coils and the connectors to which they are connected.

1.2. BOX CONTENTS

Fig. 1 on page 11 shows the contents of a PXV valve box.

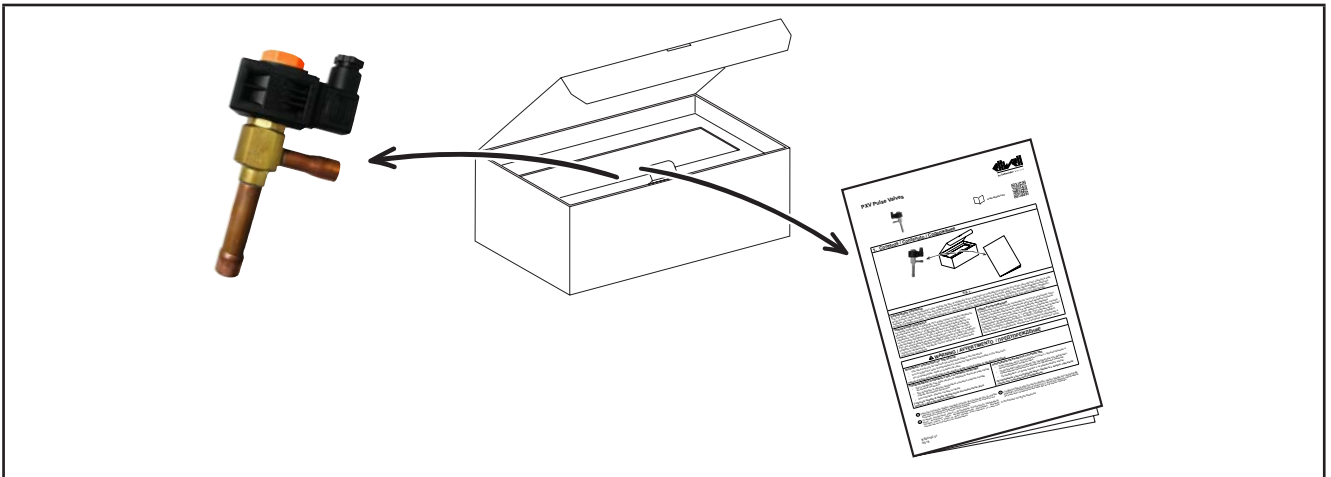

Fig. 1. Box contents

CHAPTER 2

MECHANICAL INSTALLATION

2.1. BEFORE STARTING

Before starting to install your system, read this chapter carefully.

Only the user and machine manufacturer will be aware of all the conditions and factors present during the installation and setup, operation and servicing of the machine or the process and can therefore decide which automation equipment and corresponding safety devices and interlocks can be used properly and efficiently. When choosing the automation and control equipment - and any other related equipment or software - for a particular application, you must also take account of all applicable local, regional or national standards and/or regulations.

Take particular care to comply with all information relating to safety, various electrical requirements and legal regulation which could apply to your machine or your process if using this equipment.

Please refer to the Flammable refrigerants section for important regulatory information concerning the use of these products in applications that use flammable refrigerants.

WARNING

REGULATORY INCOMPATIBILITY

Make sure that all equipment used and systems designed comply with all applicable local, regional and national laws.

Failure to follow these instructions can result in death, serious injury, or equipment damage.

2.2. DISCONNECTION FROM THE POWER SUPPLY

DANGER

RISK OF ELECTRIC SHOCK, EXPLOSION OR ARC FLASH

- Disconnect all power from all equipment including connected devices prior to removing any covers or doors, or installing or removing any accessories, hardware, cables or wires.
- Always use a properly rated voltage sensing device to confirm the power is off where and when indicated.
- Before restoring the power supply, replace and secure all covers, hardware components and cables.
- For all the devices requiring it, make sure there is an effective ground connection.
- Use only the specified voltage when operating this equipment and any associated products.
- Do not connect the device directly to the line voltage, unless expressly indicated.

Failure to follow these instructions will result in death or serious injury.

⚠ WARNING

UNINTENDED EQUIPMENT OPERATION

- Make sure the electrical connections are perfectly intact. If you notice any unusual warping, do not proceed with installation.
- Only proceed with the electrical connections once installation in the system has been completed.
- Power line and control circuits must be electrically connected in compliance with local and national regulatory requirements for the rated current and voltage of the particular equipment.
- Do not use the device in equipment or machines with safety functions.
- Tighten the orange locknut and standard locknut in compliance with the technical specifications for torque values.
- Remove and repair the valve in accordance with the requirements specified by current standards⁽¹⁾.

Failure to follow these instructions can result in death, serious injury, or equipment damage.

⁽¹⁾ The equipment must only be installed, repaired and upgraded by expert technicians in possession of the necessary qualifications and authorizations as specified by current regulations in the relevant regions. In countries within the European Union these technicians must possess refrigeration technician certification in compliance with F-GAS directive (Italian Presidential Decree N°43 dated 27/10/2012, ex EC 303/2008), in accordance with the methods indicated in the product documentation. The abovementioned personnel are also required to assume responsibility for using genuine spare parts officially supplied by Eliwell.

2.3. OPERATING ENVIRONMENT

⚠ WARNING

UNINTENDED EQUIPMENT OPERATION

Install and use this equipment in compliance with the conditions described in the "Environmental and electrical characteristics" section of this document.

Failure to follow these instructions can result in death, serious injury, or equipment damage.

2.4. COMMENTS CONCERNING INSTALLATION

During handling and assembly

⚠ CAUTION

UNINTENDED EQUIPMENT OPERATION

- Avoid placing the valve near magnetic fields for long periods of time.
- Do not subject the valve to knocks or twisting. If you notice any unusual warping, do not proceed with installation.
- Do not remove the adjustment device on the connector.

Failure to follow these instructions can result in injury or equipment damage.

2.5. PXV INSTALLATION

⚠ WARNING

UNINTENDED EQUIPMENT OPERATION

- Make sure the electrical connections are perfectly intact. If you notice any unusual warping, do not proceed with installation.
- Only proceed with the electrical connections once installation in the system has been completed.
- Power line and control circuits must be electrically connected in compliance with local and national regulatory requirements for the rated current and voltage of the particular equipment.
- Do not use the device in equipment or machines with safety functions.
- Tighten the orange locknut and standard locknut in compliance with the technical specifications for torque values.
- Remove and repair the valve in accordance with the requirements specified by current standards⁽¹⁾.

Failure to follow these instructions can result in death, serious injury, or equipment damage.

⁽¹⁾ The equipment must only be installed, repaired and upgraded by expert technicians in possession of the necessary qualifications and authorizations as specified by current regulations in the relevant regions. In countries within the European Union these technicians must possess refrigeration technician certification in compliance with F-GAS directive (Italian Presidential Decree N°43 dated 27/10/2012, ex EC 303/2008), in accordance with the methods indicated in the product documentation. The abovementioned personnel are also required to assume responsibility for using genuine spare parts officially supplied by Eliwell.

Fitting to pipes

1. Before connecting to the pipes, make sure the pipes are clean and check the flow direction.
2. Check the line voltage and use only the specified voltage when operating this equipment and any associated products.
3. Install the valve as shown (see Fig. 2). Coil pointing downwards is forbidden.
4. The valve does not need to be removed during soldering, just the coil. During this process, protect the valve body with a damp cloth and avoid direct contact with the flame.

NOTICE

INOPERABLE DEVICE

- Make sure the pipe is clean.
- Make sure the fluid flow direction matches the direction of the arrow stamped on the body.
- Make sure the line voltage matches the value stamped on the coil.

Failure to follow these instructions can result in equipment damage.

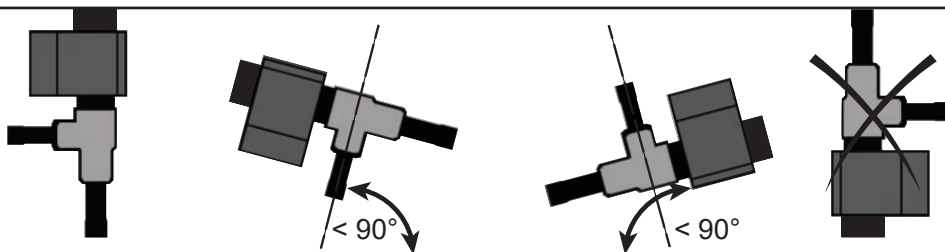

Floor/Pavimento/Boden/Suelo/Plancher/Пол/Podłoga

Fig. 2. Valve positioning

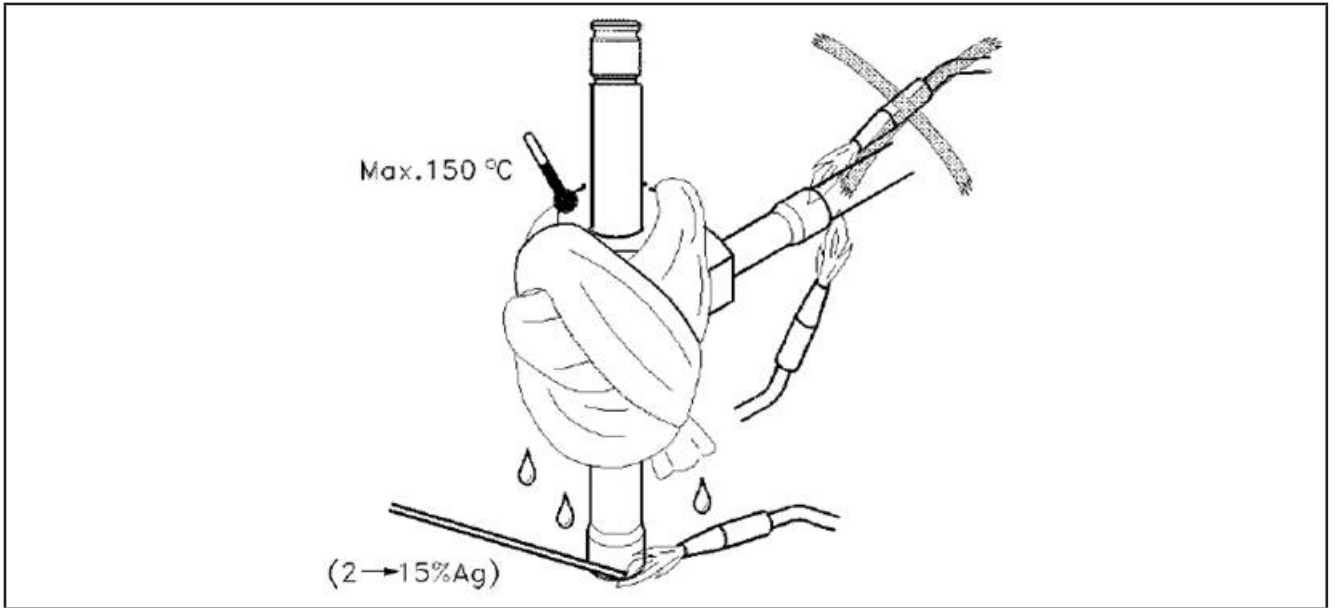

Fig. 3. Soldering

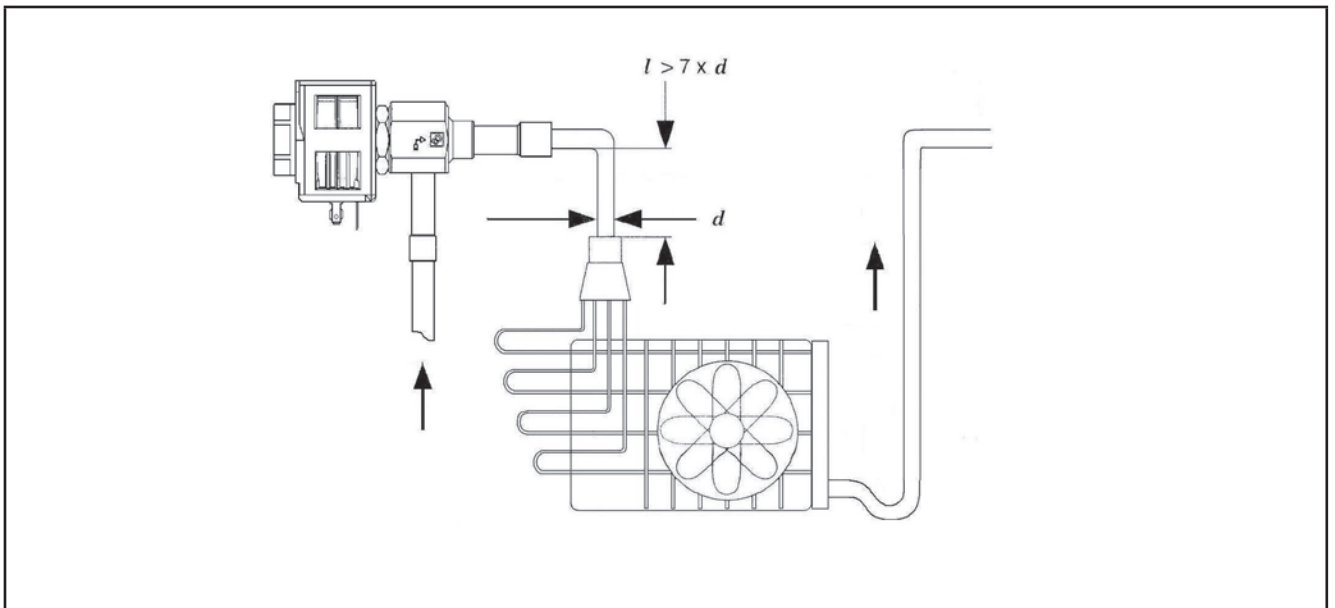

Fig. 4. Valve and evaporator details

NOTICE

INOPERABLE DEVICE

Perform an operating test on the valve assembly and driver for that specific installation.

Failure to follow these instructions can result in equipment damage.

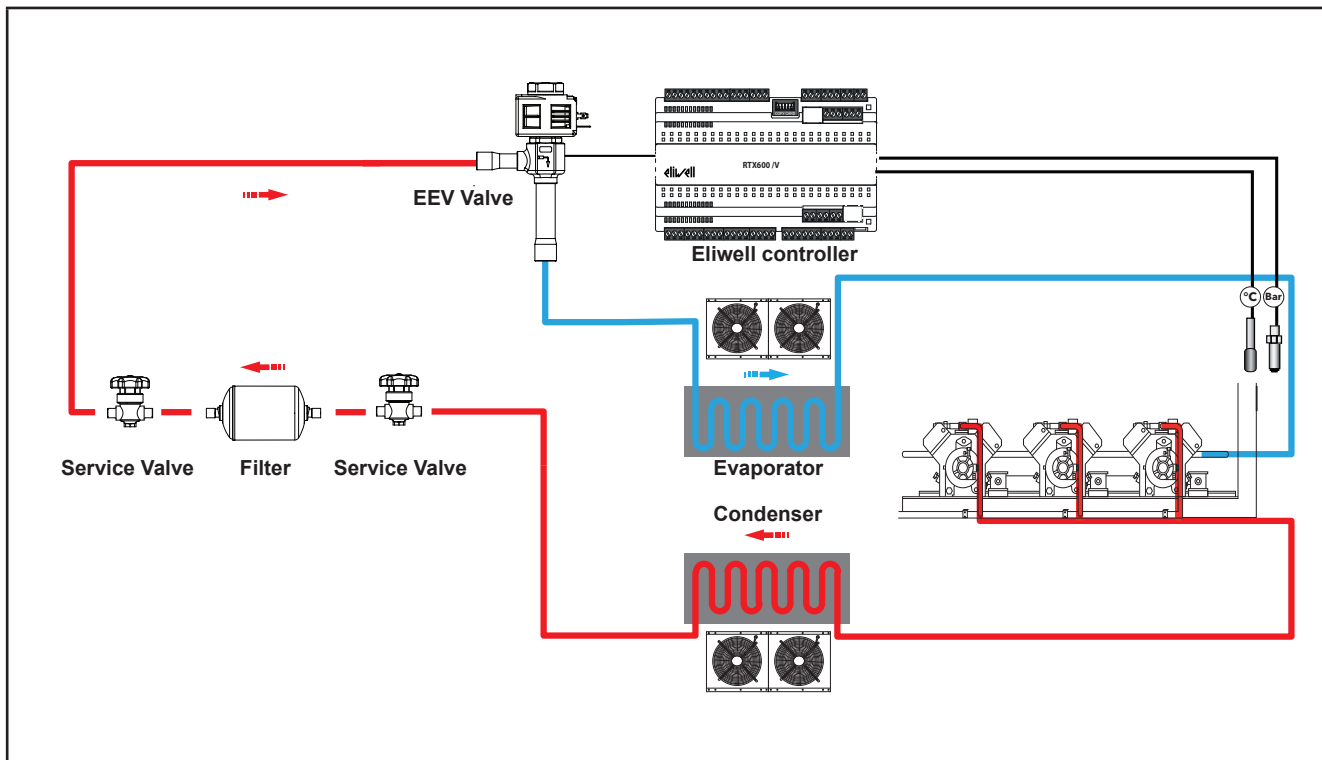

Fig. 5. Application example

LEGEND

Filter / Filtro

Service valve / Valvola di intercettazione

Condenser / Condensatore

Evaporator / Evaporatore

EEV Valve / Valvola EEV

Eliwell Controller / Controllore Eliwell

2.6. PXV SERVICING

The product consists of a coil, a body and a connector/cable.

To replace coil 4, unscrew orange locknut 1 (complete with O-Ring 2) and remove screw 3.

O-Ring 5 remains fitted on the bar.
The coil is only protected from humidity if O-Ring 5 is fitted correctly and orange locknut 1 is tightened to a torque of 1.2 - 1.4 Nm.

NOTE. To replace the orifice and change the valve potential, contact Eliwell Technical Support or an authorized Eliwell partner.

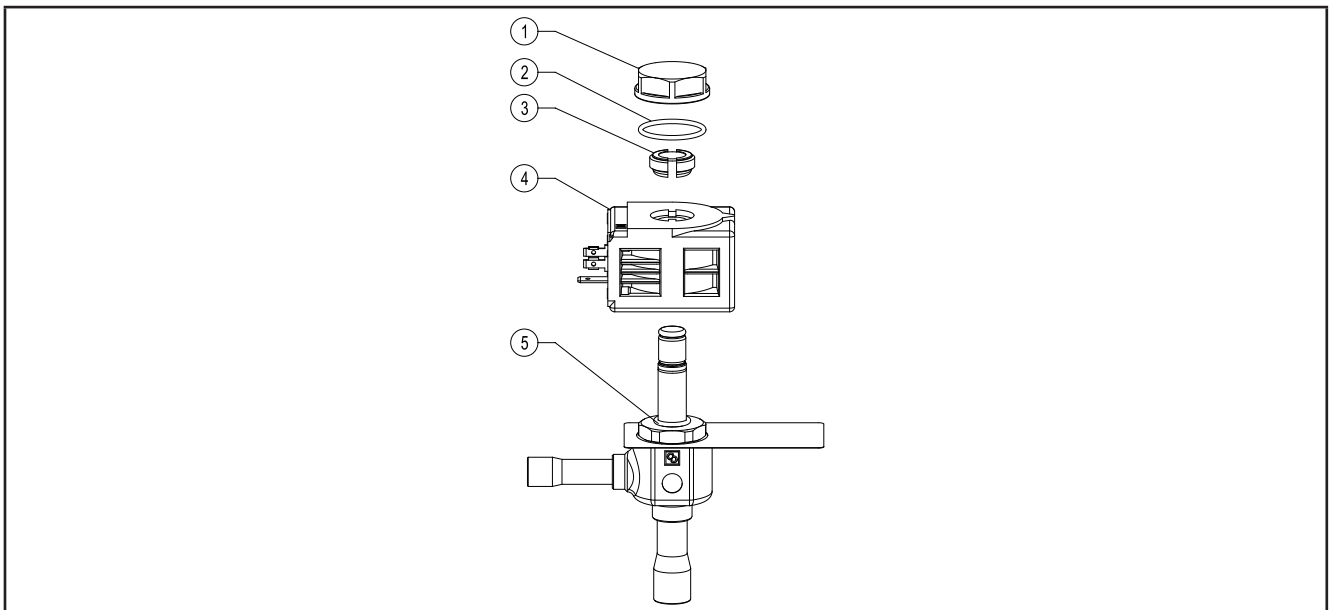

Fig. 6. coil 8 W body 03/M10

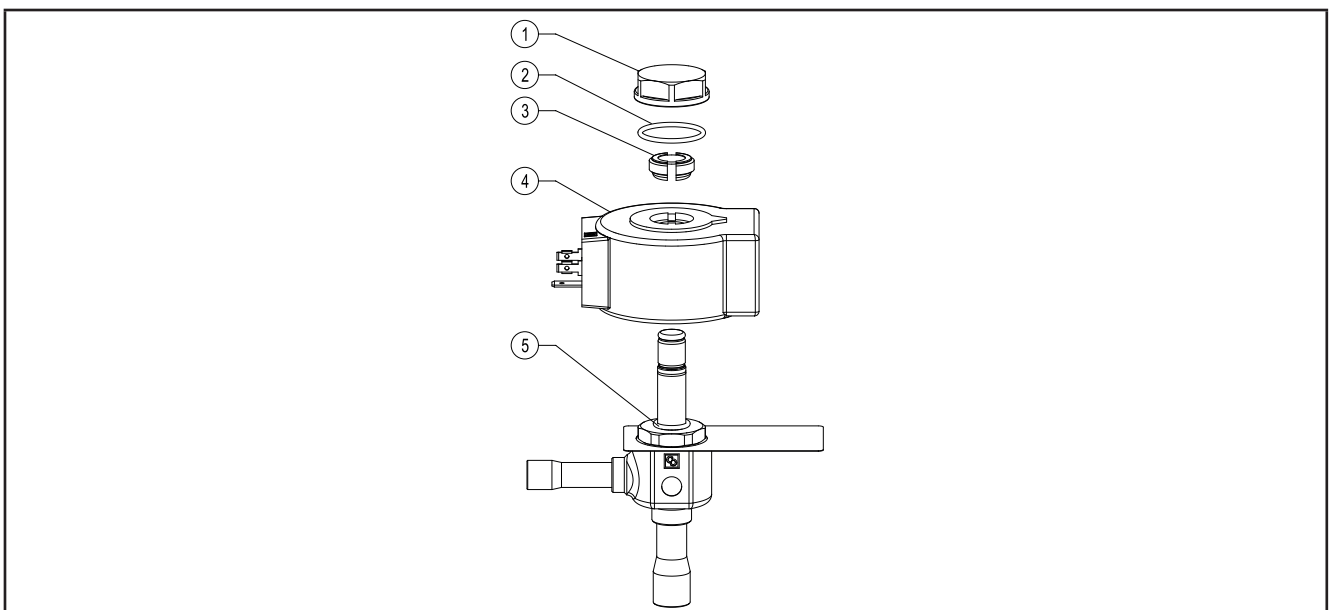

Fig. 7. coil 12 W body 03/M10

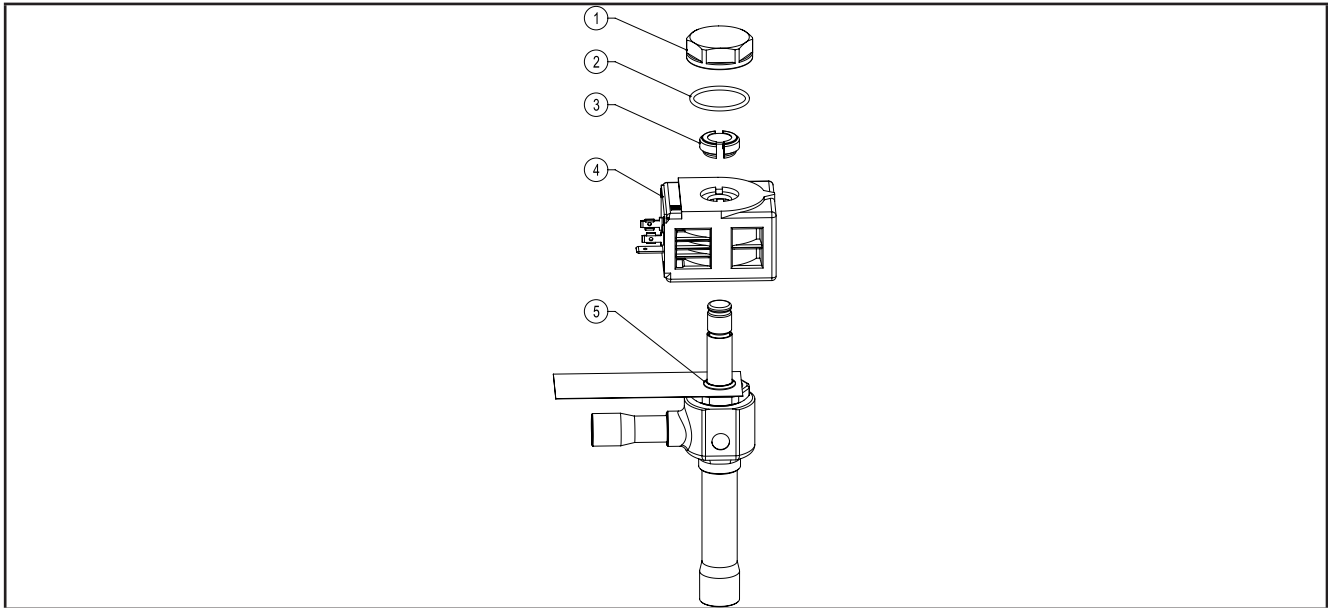

Fig. 8. coil 8 W body 04/M12

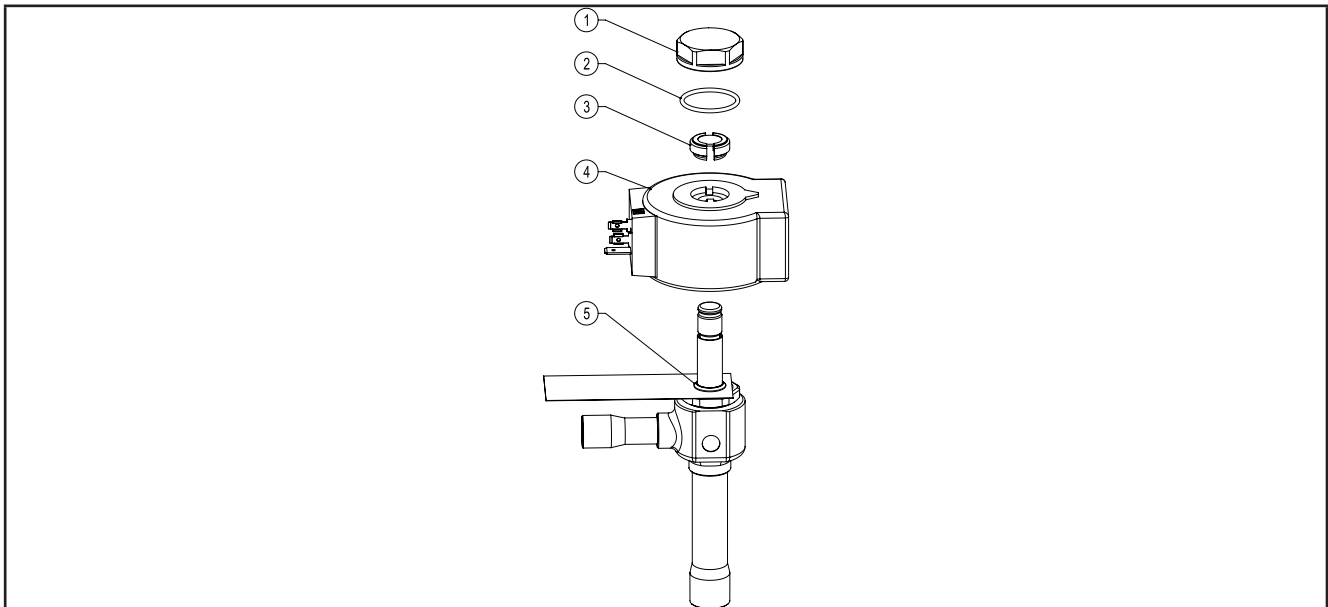

Fig. 9. coil 12 W body 04/M12

2.7. COIL + CONNECTOR

NOTICE

INOPERABLE DEVICE

- Tighten the orange locknut on the connector for cable connection.
- Carefully check the valve electrical connections.
If necessary, refer to the documentation relating to the control driver.

Failure to follow these instructions can result in equipment damage.

Coil + connector

IP65 PXVB0AR020100

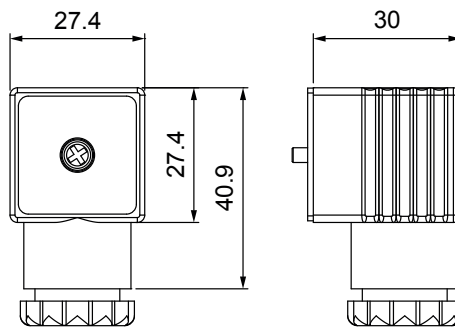

IP68 PXVB0AR030100

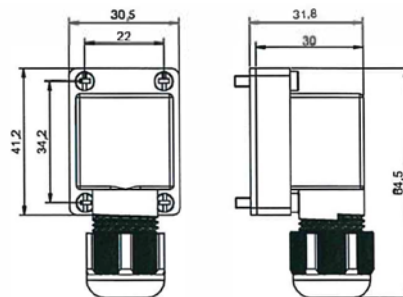

COIL MODELS

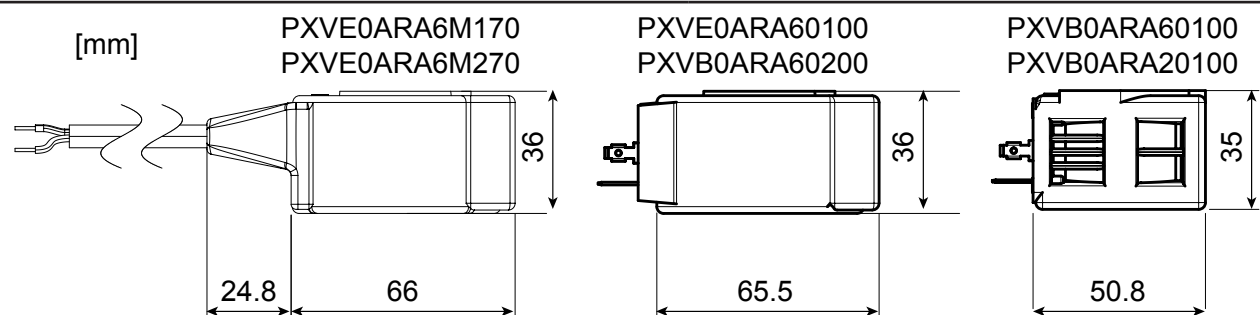

Fitting IP68 connectors

- 1 Housing
- 2 Orange locknut
- 3 Coil level gasket
- 4 Cable gasket
- 5 Contact holder
- 6 Contact screw
- 7 Self-tapping screw 3.5 x 1.6
- 8 Stainless steel screw M3 x 15.5
- 9 Power cable (not supplied)

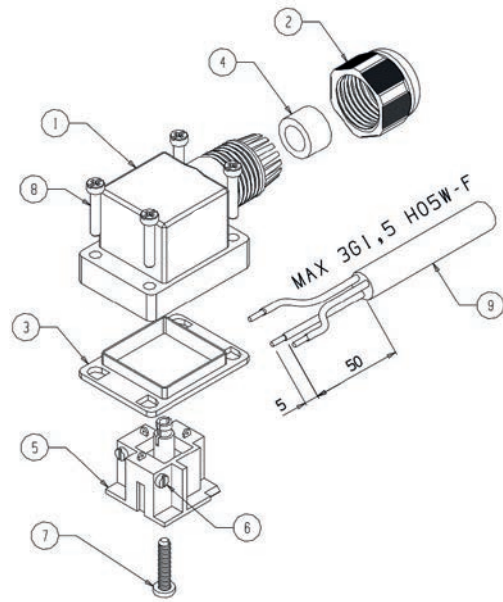

CHAPTER 3

ELECTRICAL CONNECTIONS

3.1. WIRING PRACTICES

The following information describes wiring guidelines and the practices to observe when using the device.

  **DANGER**

RISK OF ELECTRIC SHOCK, EXPLOSION OR ARC FLASH

- Disconnect all power from all devices - including connected devices - prior to removing any covers or doors, or installing or removing any accessories, hardware, cables or wires.
- Always use a properly rated voltage sensing device to confirm the power is off where and when indicated.
- Before restoring the power supply, replace and secure all covers, hardware components and cables.
- For all the devices requiring it, make sure there is an effective ground connection.
- Use only the specified voltage when operating this device and any associated products.
- Do not connect the device directly to the line voltage, unless expressly indicated.

Failure to follow these instructions will result in death or serious injury.

3.1.1. Specific considerations for handling

When handling the equipment, take care to avoid damage caused by electrostatic discharge.

The unshielded connectors are particularly vulnerable to electrostatic discharge.

 **WARNING**

UNINTENDED EQUIPMENT OPERATION DUE TO ELECTROSTATIC DISCHARGE

- Keep the equipment in the protective packaging until ready for installation.
- The device must only be installed in type-approved cupboards and/or in points that prevent unauthorized access and provide protection from electrostatic discharge.
- When handling sensitive equipment, use a grounded device protecting against electrostatic discharge.
- Before handling the equipment, always discharge the static electricity from the body by touching an earthed surface or type-approved antistatic mat.

Failure to follow these instructions can result in death, serious injury, or equipment damage.

Before carrying out any work, make sure that the device is connected to a suitable external electricity supply.

CHAPTER 4

TECHNICAL DATA

4.1. VALVE TECHNICAL DATA

Description	Models	Characteristics
System temperature (TS)	PXVB●●●●●●●●	-40 °C ... 100 °C (-40 °F ... 212 °F)
	PXVN●●●●●●●●	-40 °C ... 100 °C (-40 °F ... 212 °F)
	PXVE●●●●●●●●	-50 °C ... 100 °C (-58 °F ... 212 °F)
Ambient temperature (TA)	PXVB●●●●●●●●	-20 °C ... 50 °C (-4 °F ... 122 °F)
	PXVN●●●●●●●●	-20 °C ... 50 °C (-4 °F ... 122 °F)
	PXVE●●●●●●●●	-40 °C ... 50 °C (-40 °F ... 122 °F)
Opening differential pressure (minimum OPD)	All models	0 bar / 0 psi
Opening differential pressure (MOPD)	PXVB●●●●●●100 PXVN●●●●●●100	Orifice 1-5 : 37 bar (537 psi) Orifice 6 : 27 bar (392 psi) Orifice 7-9 : 18 bar (261 psi)
SILENT RANGE Opening differential pressure (MOPD)	PXVN●●●●●●200	Orifice 1-6 : 35 bar (508 psi) Orifice 7 : 24 bar (348 psi)
Opening differential pressure (MOPD)	PXVE●●●●●●100	Orifice 1-6 : 37 bar (537 psi) Orifice 7 : 35 bar (508 psi) Orifice 8 : 30 bar (435 psi) Orifice 9 : 25 bar (363 psi)
SILENT RANGE Opening differential pressure (MOPD)	PXVE●●●●●●200	Orifice 1-6 : 35 bar (508 psi) Orifice 7 : 24 bar (348 psi)
Maximum working pressure	PXVB●●●●●●●●	45 bar / 653 psi
	PXVN●●●●●●●●	45 bar / 653 psi
	PXVE●●●●●●●●	80 bar / 1160 psi
Blowout pressure	All models	PXVN/PXVB = 225 bar (3263 psi) PXVE = 240 bar (3481 psi)
PED	All models	ART. 4.3 of 2014/68/EU
Operating principle	All models	PWM
Minimum run time	All models	1 second

4.2. COIL TECHNICAL DATA

coil / connector code	voltage ⁽¹⁾	power supply tolerance (%)	frequency (Hz)	power (W)	insulation class	MOPD		connections
						orifice		
						1 to 4	5 to 9	
PXVB0ARA60100	220/230 Vac	+6 / -10	50/60	8	F	35	22	connector IP 65 PXVB0AR020100 connector IP 68 PXVB0AR030100
PXVB0ARA6A172	220/230 Vac	+6 / -10	50/60	8	F	35	22	cable and connector 7, 2, assembled
PXVE0ARA60100	220/230 Vac	+6 / -10	50/60	12	F	> 45 < 80	> 45 < 80	connector IP 65 PXVB0AR020100
PXVE0ARA6M170	220/230 Vac	+6 / -10	50/60	12	F	> 45 < 80	> 45 < 80	overmoulded cable coil 7.0 m
PXVB0ARA20100	24 Vac	+10 / -10	50/60	8	F	35	25	connector IP 65 PXVB0AR020100 connector IP 68 PXVB0AR030100
PXVB0ARA20200	220 Vdc	+10 / -5	-	18	F	35 ⁽²⁾	24 ⁽³⁾	connector IP 65 PXVB0AR020100 PXVB0AR020200 with rectifier
PXVE0ARA6M270	220 Vdc	+10 / -5	-	18	F	35 ⁽²⁾	24 ⁽³⁾	overmoulded cable coil 7.0 m and label

⁽¹⁾ consult the sales office for other power supplies

⁽²⁾ up to orifice 6

⁽³⁾ orifice 7 only

WARNING

UNINTENDED EQUIPMENT OPERATION

Do not exceed any of the rated values specified in the environmental and electrical characteristics tables.

Failure to follow these instructions can result in death, serious injury, or equipment damage.

4.3. APPROVALS

Models	Connections	PED 2014/68/EU	
		PS	Refrigerant
PXVB0●●●●●●100	3/8' - 1/2'	45 bar	HFC - HFO - HCFC (1)
PXVN0●●●●●●100	1/2' - 5/8'		
PXVBM●●●●●●100	10 mm - 12 mm		
PXVNM●●●●●●100	12 mm - 16 mm		
PXVE0●●●●●●100	3/8' - 1/2'	80 bar	R744
PXVEM●●●●●●100	10 mm - 12 mm 12 mm - 16 mm		
PXVN0●●●●●●200	3/8' - 1/2'	45 bar	HFC - HFO - HCFC (1)
PXVNM●●●●●●200	10 mm - 12 mm		
PXVE0●●●●●●200	3/8' - 1/2'	80 bar	R744
PXVEM●●●●●●200	10 mm - 12 mm		

- (1) HFC=R134a, R23, R32, R404A, R407C, R410A, R507
HFO= R1234yf, R1234ze, R448A, R449A, R450A, R452A
HC= R290, R600, R600a
HCFC= R22

NOTE. These products cannot be used in the United States and Canada.

4.4. MECHANICAL CHARACTERISTICS

PXVN models

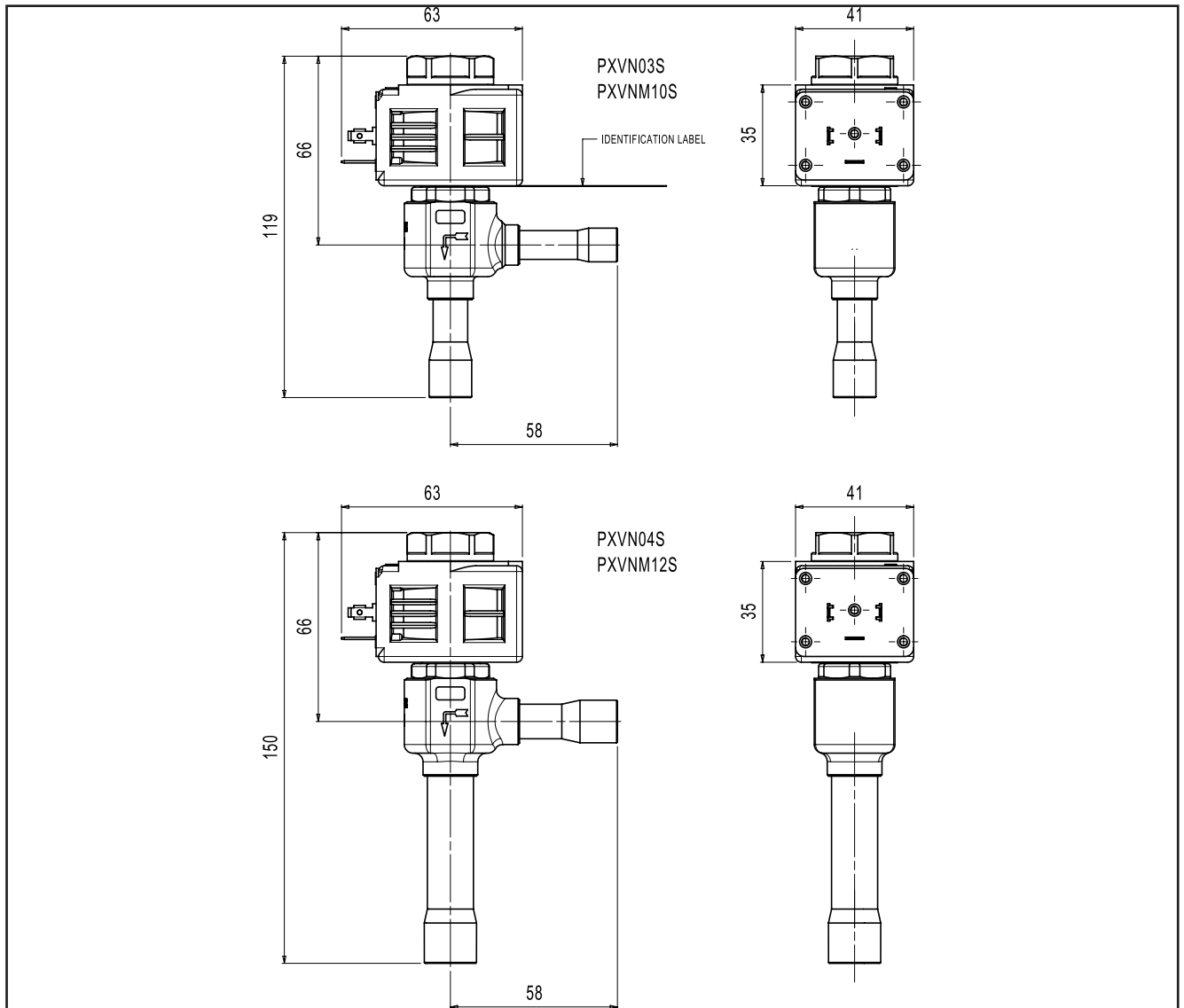

Fig. 10. PXVN mechanical dimensions

PXVB models

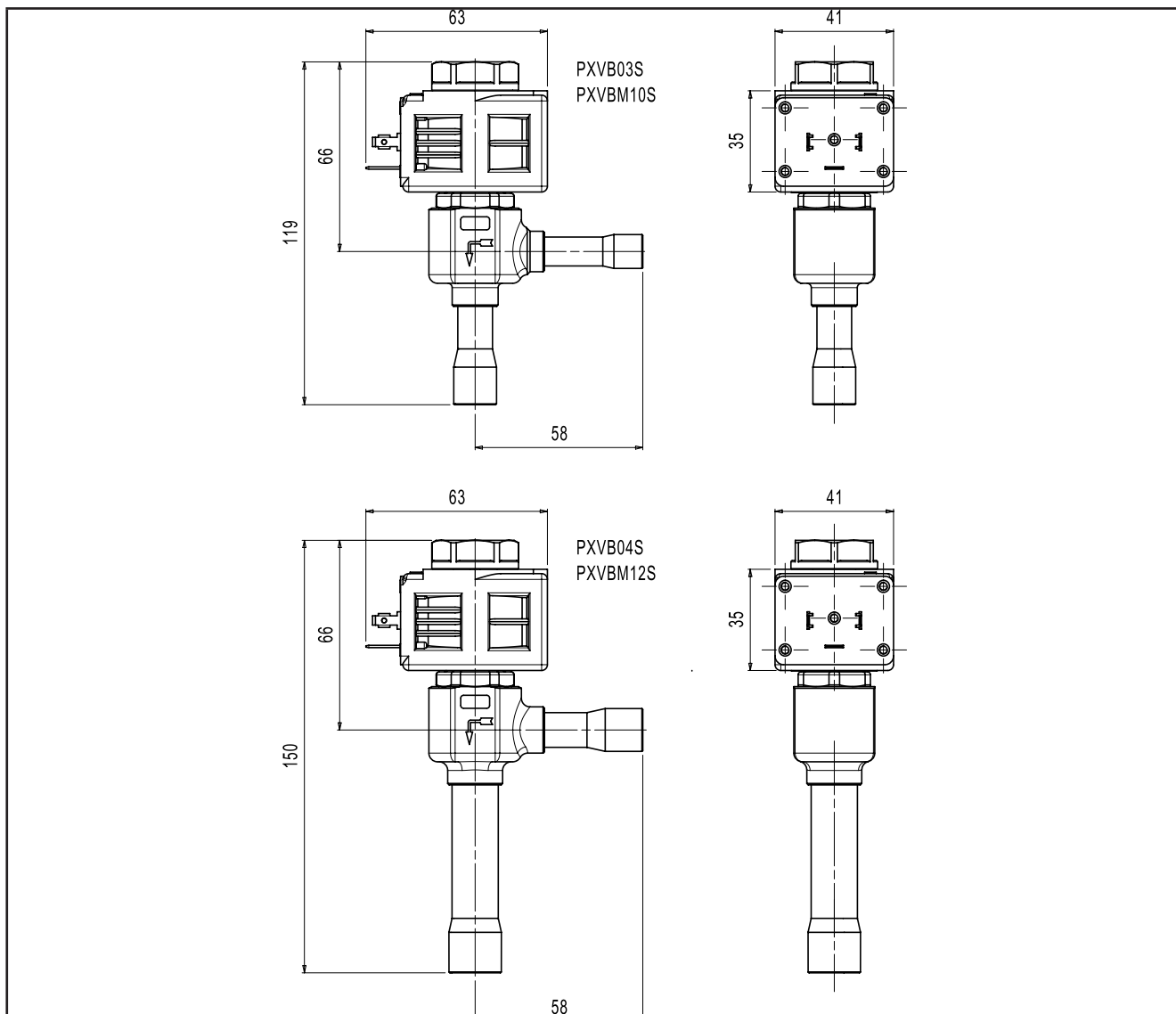

Fig. 11. PXVB mechanical dimensions

PXVE models

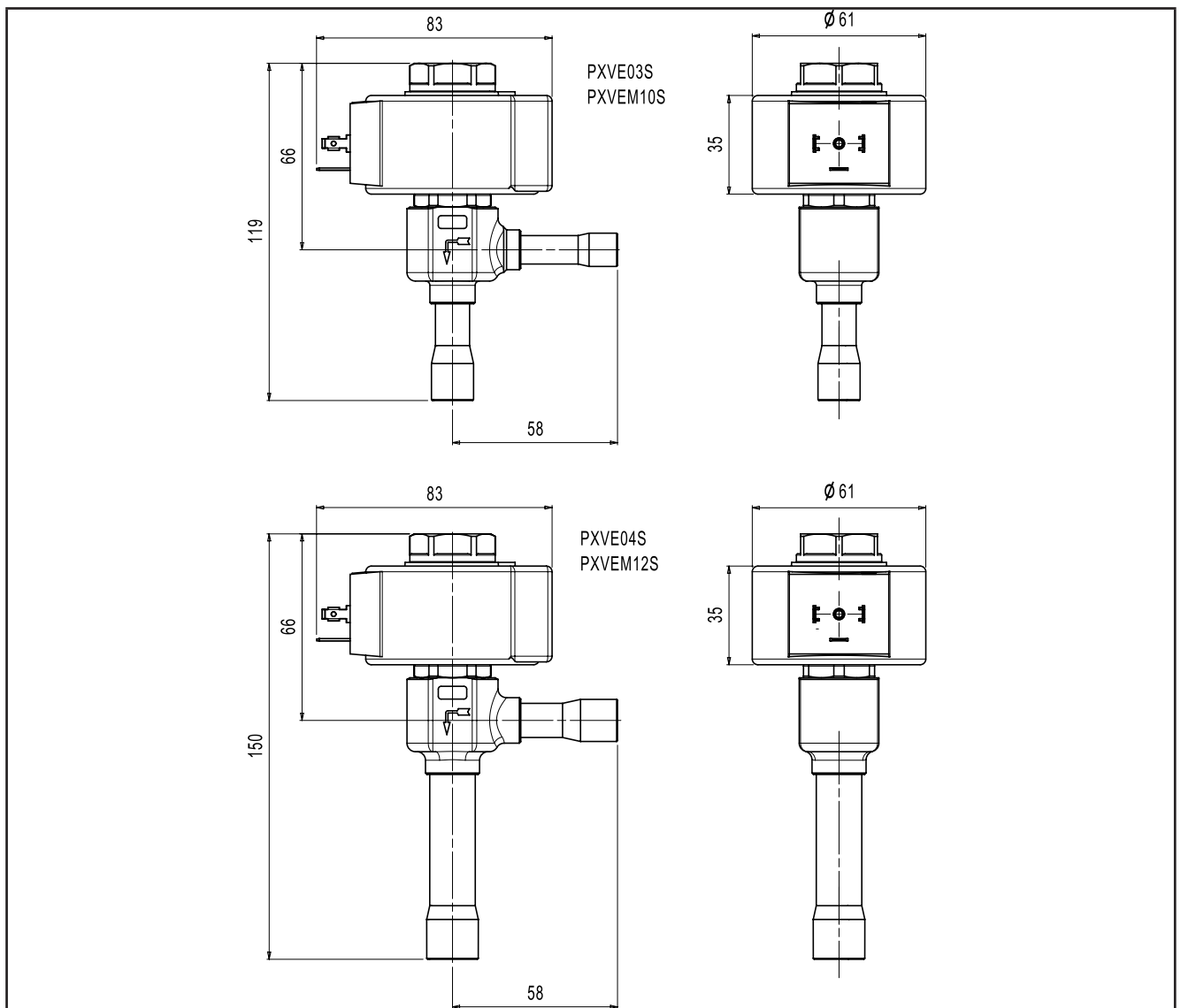

Fig. 12. PXVE mechanical dimensions

CHAPTER 5

SPARE PART KIT AND O-RING SET

5.1. SILENT SPARE PART KIT AND O-RING SET TABLE

Type	Description	Code	Description	Compatible refrigerants
PXVN	PXVN SILENT SPARE PART	PXVN0ER000200	silent bar green O-Ring filter movable part	HCFC, HFC, HFO, HC
	PXVN O-Ring SET 8 pcs	PXVN0DR000100	8 x green O-Rings 8 x filters	HCFC, HFC, HFO, HC
PXVE	PXVE SILENT SPARE PART	PXVE0CR000200	silent bar purple O-Ring filter movable part	CO ₂
	PXVE O-Ring SET 8 pcs	PXVE0BR000100	8 x purple O-Rings 8 x filters	CO ₂

WARNING

UNINTENDED EQUIPMENT OPERATION

- The valve cannot be used with refrigerants other than those listed in this document.
- Do not subject the valve to temperatures or pressures higher than those listed in this document.
- Tighten the orange locknut and standard locknut in compliance with the technical specifications for torque values.
- Remove and repair the valve in accordance with the requirements specified by current standards⁽¹⁾.

Failure to follow these instructions can result in death, serious injury, or equipment damage.

⁽¹⁾ The equipment must only be installed, repaired and upgraded by expert technicians in possession of the necessary qualifications and authorizations as specified by current regulations in the relevant regions. In countries within the European Union these technicians must possess refrigeration technician certification in compliance with F-GAS directive (Italian Presidential Decree N°43 dated 27/10/2012, ex EC 303/2008), in accordance with the methods indicated in the product documentation. The abovementioned personnel are also required to assume responsibility for using genuine spare parts officially supplied by Eliwell.

5.2. SPARE PART KIT AND O-RING SET FITTING

The instructions for replacing the O-Ring and the bar only apply to silent models.

- The sequence for replacing just the O-Ring is 1-2-3-4a-5-6a-7...10
- The sequence for replacing the bar, movable part and O-Ring is 1-2-3-4b-5-6b-7...10

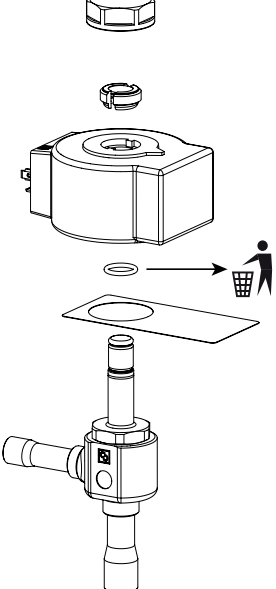
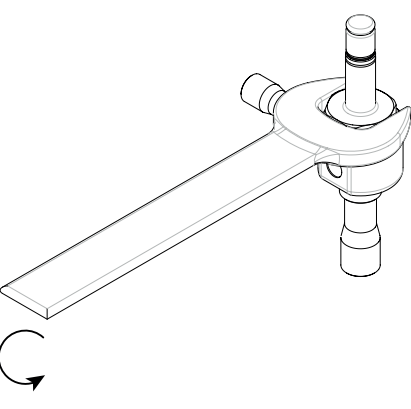
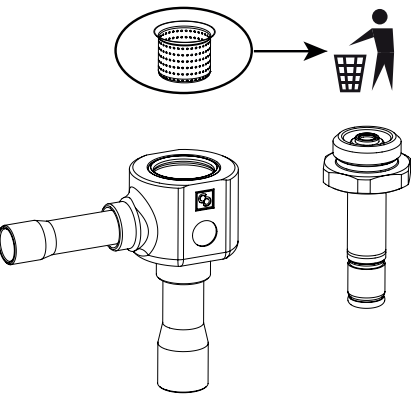
No.	Kit Assembly	
1	Remove the coil and throw away the O-Ring.	
2	Unscrew the valve.	
3	Remove the filter and replace it with a new one.	

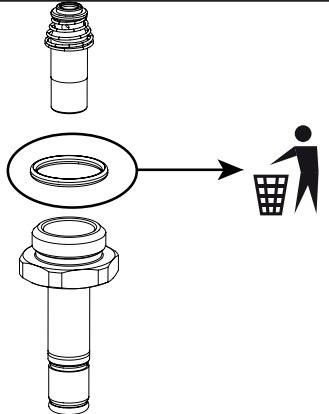
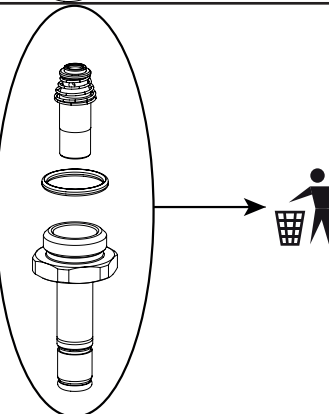
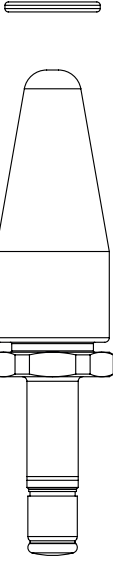
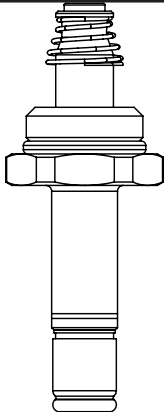
4a	Remove the O-Ring and discard it.	
4b	Remove the movable part, the bar and the O-Ring and discard them.	
5	<p>Insert the new O-Ring using a suitable tool. Use the conical tool code PXVS0GR000000 to position the O-Ring in the relevant place. Check the color of the new O-Ring: an incorrect color could cause the valve to no longer be intact.</p> <div style="border: 1px solid black; padding: 5px; margin-top: 10px;"> <p style="text-align: center;">NOTICE</p> <p>INOPERABLE DEVICE</p> <ul style="list-style-type: none"> • Only use the green O-Ring for model N. • Only use the purple O-Ring for model E. <p>Failure to follow these instructions can result in equipment damage.</p> </div>	
6a	Insert the movable part into the bar.	

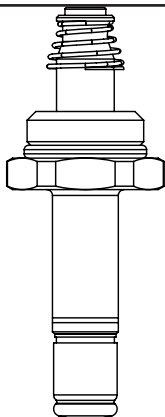
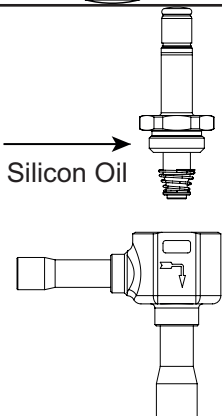
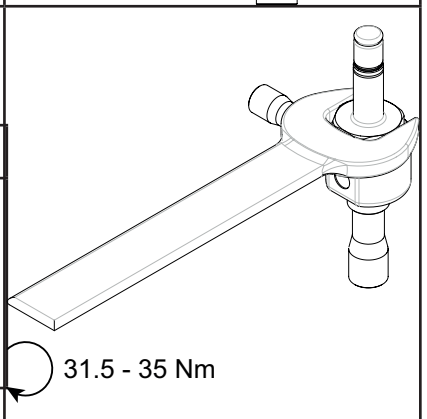
6b	Insert the new movable part into the bar.	
7	<ol style="list-style-type: none"> 1. Grease the O-Ring with a silicon oil. 2. Fit the bar and the movable part onto the valve body. 3. Use permanent magnet code PXVS0FR000000 to hold the movable part to the bar before assembly. 	
8	<p>Screw the pipe to the indicated tightening torque (31.5 - 35 Nm).</p> <div style="border: 1px solid black; padding: 5px; margin-top: 10px;"> <p style="text-align: center;">⚠ WARNING</p> <p>UNINTENDED EQUIPMENT OPERATION</p> <p>Tighten the orange locknut in compliance with the technical specifications for torque values.</p> <p>Failure to follow these instructions can result in death, serious injury, or equipment damage.</p> </div>	

9	<p>1. Add the label supplied with the spare parts kit to the label that was there before.</p> <p>2. Insert the new O-Ring and the coil.</p> <p>Notes</p> <p>a) The Kit is designed to upgrade non-silent versions to silent operation. Consult the relevant Hardware Guide to select the appropriate coil.</p> <p>b) Place the label plates as indicated in figure..</p> <div style="border: 1px solid black; padding: 5px; text-align: center;">NOTICE</div> <div style="border: 1px solid black; padding: 5px;"> <p>IP DEGREE LOSS AND COIL DAMAGE</p> <p>Make sure there is no interference with labels between the valve body, O-ring and coil.</p> <p>Failure to follow these instructions can result in equipment damage.</p> </div> <div style="border: 1px solid black; padding: 5px; text-align: center;">NOTICE</div> <div style="border: 1px solid black; padding: 5px;"> <p>INOPERABLE DEVICE</p> <ul style="list-style-type: none"> • Position the labels correctly. • Only use 220 Vdc coils for silent models and 220/230 Vac coils for non-silent models. <p>Failure to follow these instructions can result in equipment damage.</p> </div>	
10	<p>Screw the orange nut to the indicated tightening torque (1.2 - 1.4 Nm).</p> <div style="border: 1px solid black; padding: 5px; text-align: center;">⚠ WARNING</div> <div style="border: 1px solid black; padding: 5px;"> <p>UNINTENDED EQUIPMENT OPERATION</p> <p>Tighten the nut in compliance with the technical specifications for torque values.</p> <p>Failure to follow these instructions can result in death, serious injury, or equipment damage.</p> </div>	

CHAPTER 6

GENERAL VALVE CHARACTERISTICS TABLE

6.1. GENERAL VALVE BODY CHARACTERISTICS TABLE

Silent PXVN models | Refrigerants HFO-HFC-HC

code	orifice	hole	ods connections				Kv factor	capacity refrigerant				
			inches		mm			R134a	R507	R407C	R410A	R290
			in	out	in	out						
PXVNM10S01200	1	0.5	-	-	10	12	0.010	0.8	0.77	1.03	1.47	1.10
PXVN03S010200	1	0.5	3/8"	1/2"	-	-						
PXVNM10S02200	2	0.7	-	-	10	12	0.017	1.5	1.6	1.9	2.7	2.20
PXVN03S020200	2	0.7	3/8"	1/2"	-	-						
PXVNM10S03200	3	0.8	-	-	10	12	0.023	1.8	2.0	2.2	3.4	2.70
PXVN03S030200	3	0.8	3/8"	1/2"	-	-						
PXVNM10S04200	4	1.1	-	-	10	12	0.043	2.9	3.0	3.5	5.5	4.20
PXVN03S040200	4	1.1	3/8"	1/2"	-	-						
PXVNM10S05200	5	1.3	-	-	10	12	0.065	4.9	5.3	6.2	9.5	7.40
PXVN03S050200	5	1.3	3/8"	1/2"	-	-						
PXVNM10S06200	6	1.7	-	-	10	12	0.113	6.8	7.2	8.4	12.9	10.10
PXVN03S060200	6	1.7	3/8"	1/2"	-	-						
PXVNM10S07200	7	2.3	-	-	10	12	0.200	10.7	11.6	14.2	20.6	16.10
PXVN03S070200	7	2.3	3/8"	1/2"	-	-						

PXVN models | Refrigerants HFO-HFC-HC

code	orifice	hole	ods connections				Kv factor	capacity refrigerant				
			inches		mm			R134a	R507	R407C	R410A	R290
			in	out	in	out						
PXVN03S010100	1	0.5	3/8"	1/2"	-	-	0.010	0.8	0.77	1.03	1.47	1.10
PXVN03S01100	1	0.5	-	-	10	12						
PXVN03S020100	2	0.7	3/8"	1/2"	-	-	0.017	1.5	1.6	1.9	2.7	2.20
PXVN03S02100	2	0.7	-	-	10	12						
PXVN03S030100	3	0.8	3/8"	1/2"	-	-	0.023	1.8	2.0	2.2	3.4	2.70
PXVN03S03100	3	0.8	-	-	10	12						
PXVN03S040100	4	1.1	3/8"	1/2"	-	-	0.043	2.9	3.0	3.5	5.5	4.20
PXVN03S04100	4	1.1	-	-	10	12						
PXVN03S050100	5	1.3	3/8"	1/2"	-	-	0.065	4.9	5.3	6.2	9.5	7.40
PXVN03S05100	5	1.3	-	-	10	12						
PXVN03S060100	6	1.7	3/8"	1/2"	-	-	0.113	6.8	7.2	8.4	12.9	10.10
PXVN03S06100	6	1.7	-	-	10	12						
PXVN03S070100	7	2.3	3/8"	1/2"	-	-	0.200	10.7	11.6	14.2	20.6	16.10
PXVN03S07100	7	2.3	-	-	10	12						
PXVN04S070100	7	2.3	1/2"	5/8"	-	-	0.200	10.7	11.6	14.2	20.6	16.10
PXVN04S07100	7	2.3	-	-	12	16						
PXVN04S080100	8	2.5	1/2"	5/8"	-	-	0.230	12.9	13.8	16.4	24.5	19.40
PXVN04S08100	8	2.5	-	-	12	16						
PXVN04S090100	9	2.7	1/2"	5/8"	-	-	0.250	14.4	15.4	18.1	27.3	21.60
PXVN04S09100	9	2.7	-	-	12	16						

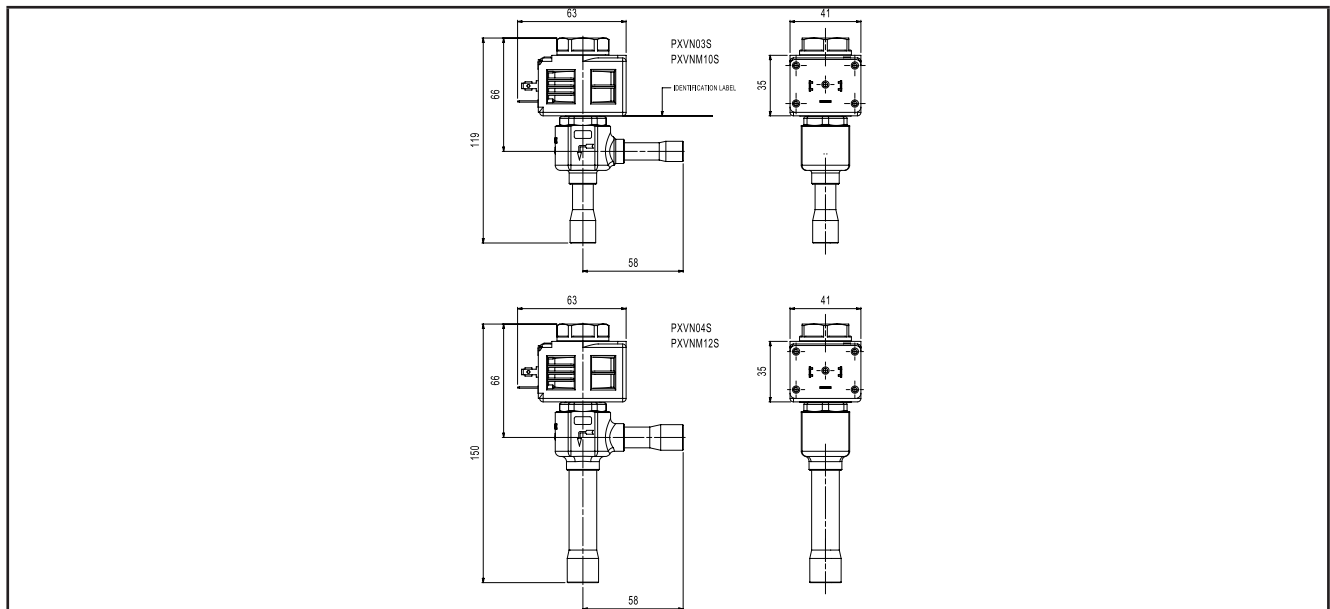

Fig. 13. PXVN shape

PXVB models | Refrigerants HCFC-HFC

code	orifice	hole	ods connections				Kv factor	capacity refrigerant	
			inches		mm			R22	R404A
			in	out	in	out			
PXVB03S010100	1	0.5	3/8"	1/2"	-	-	0.010	0.93	0.77
PXVBM10S01100	1	0.5	-	-	10	12			
PXVB03S020100	2	0.7	3/8"	1/2"	-	-	0.017	1.7	1.6
PXVBM10S02100	2	0.7	-	-	10	12			
PXVB03S030100	3	0.8	3/8"	1/2"	-	-	0.023	2.0	1.9
PXVBM10S03100	3	0.8	-	-	10	12			
PXVB03S040100	4	1.1	3/8"	1/2"	-	-	0.043	3.2	3.0
PXVBM10S04100	4	1.1	-	-	10	12			
PXVB03S050100	5	1.3	3/8"	1/2"	-	-	0.065	5.6	5.2
PXVBM10S05100	5	1.3	-	-	10	12			
PXVB03S060100	6	1.7	3/8"	1/2"	-	-	0.113	7.6	7.1
PXVBM10S06100	6	1.7	-	-	10	12			
PXVB03S070100	7	2.3	3/8"	1/2"	-	-	0.200	12.8	11.4
PXVBM10S07100	7	2.3	-	-	10	12			
PXVB04S070100	7	2.3	1/2"	5/8"	-	-	0.200	12.8	11.4
PXVBM12S07100	7	2.3	-	-	12	16			
PXVB04S080100	8	2.5	1/2"	5/8"	-	-	0.230	14.8	13.7
PXVBM12S08100	8	2.5	-	-	12	16			
PXVB04S090100	9	2.7	1/2"	5/8"	-	-	0.250	16.3	15.2
PXVBM12S09100	9	2.7	-	-	12	16			

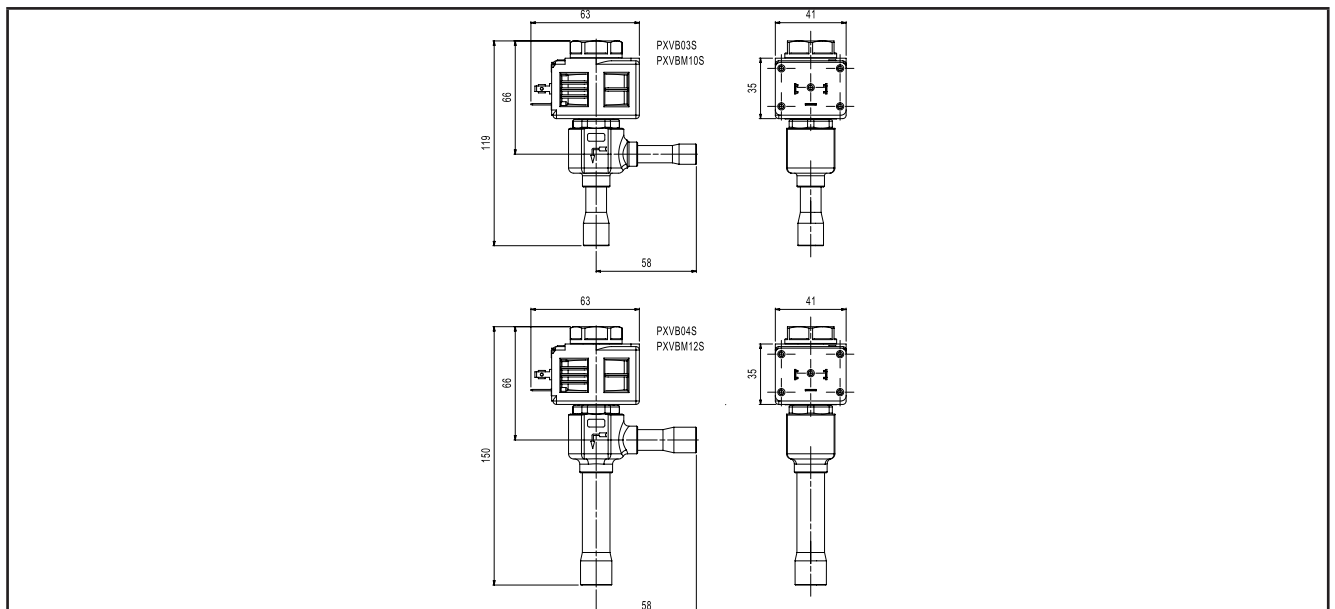

Fig. 14. PXVB shape

Silent PXVE models | Refrigerant R744

code	orifice	hole	ods connections				Kv factor	capacity refrigerant
			inches		mm			R744
			in	out	in	out		
PXVEM10S01200	1	0.5	-	-	10	12	0.010	2.6
PXVE03S010200	1	0.5	3/8"	1/2"	-	-		
PXVEM10S02200	2	0.7	-	-	10	12	0.017	4.4
PXVE03S020200	2	0.7	3/8"	1/2"	-	-		
PXVEM10S03200	3	0.8	-	-	10	12	0.023	5.8
PXVE03S030200	3	0.8	3/8"	1/2"	-	-		
PXVEM10S04200	4	1.1	-	-	10	12	0.043	9.1
PXVE03S040200	4	1.1	3/8"	1/2"	-	-		
PXVEM10S05200	5	1.3	-	-	10	12	0.065	15.7
PXVE03S050200	5	1.3	3/8"	1/2"	-	-		
PXVEM10S06200	6	1.7	-	-	10	12	0.113	21.4
PXVE03S060200	6	1.7	3/8"	1/2"	-	-		
PXVEM10S07200	7	2.3	-	-	10	12	0.200	34.3
PXVE03S070200	7	2.3	3/8"	1/2"	-	-		

PXVE models | Refrigerant R744

code	orifice	hole	ods connections				Kv factor	capacity refrigerant
			inches		mm			R744
			in	out	in	out		
PXVE03S000100	0	0.3	3/8"	1/2"	-	-	0.003	1.04
PXVEM10S00100	0	0.3	-	-	10	12		
PXVE03S010100	1	0.5	3/8"	1/2"	-	-	0.010	2.6
PXVEM10S01100	1	0.5	-	-	10	12		
PXVE03S020100	2	0.7	3/8"	1/2"	-	-	0.017	4.4
PXVEM10S02100	2	0.7	-	-	10	12		
PXVE03S030100	3	0.8	3/8"	1/2"	-	-	0.023	5.8
PXVEM10S03100	3	0.8	-	-	10	12		
PXVE03S040100	4	1.1	3/8"	1/2"	-	-	0.043	9.1
PXVEM10S04100	4	1.1	-	-	10	12		
PXVE03S050100	5	1.3	3/8"	1/2"	-	-	0.065	15.7
PXVEM10S05100	5	1.3	-	-	10	12		
PXVE03S060100	6	1.7	3/8"	1/2"	-	-	0.113	21.4
PXVEM10S06100	6	1.7	-	-	10	12		
PXVE03S070100	7	2.3	3/8"	1/2"	-	-	0.200	34.3
PXVEM10S07100	7	2.3	-	-	10	12		
PXVE04S070100	7	2.3	1/2"	5/8"	-	-	0.200	34.3
PXVEM12S07100	7	2.3	-	-	12	16		
PXVE04S080100	8	2.5	1/2"	5/8"	-	-	0.230	41.5
PXVEM12S08100	8	2.5	-	-	12	16		
PXVE04S090100	9	2.7	1/2"	5/8"	-	-	0.250	46.3
PXVEM12S09100	9	2.7	-	-	12	16		

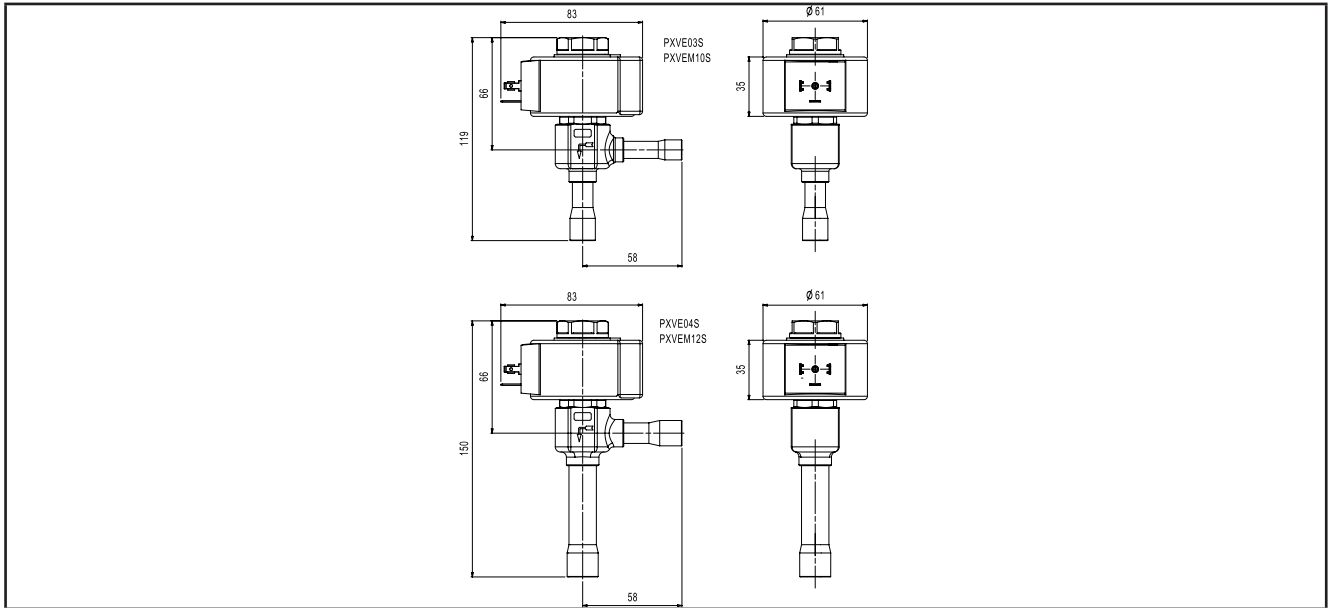

Fig. 15. PXVE shape

CHAPTER 7

VALVE SELECTION

SELECTION

To size a PXV valve in a refrigeration system correctly, the following design parameters must be available:

- Type of refrigerant
- Evaporator potential; Q_e
- Evaporation temperature/pressure; T_e / p_e
- Minimum condensation temperature / pressure; T_c / p_c
- Temperature of the liquid refrigerant as it enters the valve; T_l
- Pressure drop in the liquid line, distributor, evaporator; Δp

The procedure described below will help to correctly size an expansion valve in a refrigeration system.

Step 1

Determine the pressure drop across the valve

The pressure drop is calculated using the formula:

$$\Delta p_{\text{tot}} = p_c - (p_e + \Delta p)$$

where:

- p_c = condensation pressure
- p_e = evaporation pressure
- Δp = sum of the pressure drops in the liquid line, distributor, evaporator at maximum flow rate, i.e. with the valve always open

Step 2

Correct the evaporator potential when sub-cooling occurs

The evaporator potential Q_e must be suitably corrected based on the sub-cooling value. Sub-cooling is calculated using the formula:

$$\Delta_{\text{sub}} = T_c - T_l$$

Use the table of sub-cooling correction factors to select a suitable correction factor F_{sub} , corresponding to the calculated value Δ_{sub} , and determine the potential required from the valve using the formula:

$$Q_{\text{sub}} = F_{\text{sub}} \cdot Q_e$$

Step 3

Correct the potential based on the application

For the valve to work properly, it must be oversized so that, in the test period, it remains closed for between 50% and 25% of the time. The choice of this power margin depends on the application, which may anticipate peaks in the flow rate to varying extents, and on the control algorithm used by the electronics junction box.

In general, however, this correction factor F_{ev} is closely linked to the evaporation temperature T_e and can be considered as equal to 125% for $T_e \geq -15^\circ\text{C}$ and 150% for $T_e < -15^\circ\text{C}$. These general values should nevertheless be checked in line with the specific application.

The capacity of the valve should therefore be at least equal to:

$$Q_{ev} = F_{evb} \cdot Q_{sub}$$

Step 4

Determine the required orifice size.

Use the pressure across the valve, the evaporation temperature and the correct potential Q_{ev} calculated above to select the corresponding orifice size from the table of potential values corresponding to the selected refrigerant fluid.

Step 5

Liquid line sizing

As the valve has on-off operating criteria, during the opening phase the flow rate may rise considerably in relation to its average value in the period. For this very reason, the designer should size the diameter of the liquid line pipes in accordance with the maximum flow rate exiting the orifice under actual conditions of Δp_{tot} and so that the load loss does not cause a reduction in the maximum valve power.

SIZING EXAMPLE

- Type of refrigerant R404A
- Evaporator potential; Q_e 2.8 kW
- Evaporation temperature; T_e -5 °C
- Minimum condensation temperature; T_c + 37 °C
- Liquid refrigerant temperature; T_l + 20 °C
- Pressure drop in the liquid line, distributor, evaporator; Δp 2 bar

Step 1

Determine the pressure drop across the valve

- Condensation pressure at + 37 °C - $p_c = 16.9$ bar
- Evaporation pressure at - 5 °C - $p_e = 5.17$ bar

$$\Delta p_{\text{tot}} = 16.9 - (5.17 + 2) = 9.73 \text{ bar}$$

Step 2

Determine the required valve potential

$$\Delta T_{\text{sub}} = 37 - 20 = 17^\circ\text{C}$$

In the table of sub-cooling correction factors, in line with the value $\Delta T_{\text{sub}} = 17^\circ\text{C}$, we get a correction factor F_{sub} of 0.83. The required valve potential is:

$$Q_{\text{sub}} = 0.83 \cdot 2.8 = 2.324 \text{ kW}$$

Step 3

Correct the potential based on the application

Based on the general criteria mentioned above, we apply a 25% increase to the potential we have just calculated:

$$Q_{\text{ev}} = 1.25 \cdot 2.324 = 2.91 \text{ kW}$$

Step 4

Determine the required orifice size

Using the potential table for refrigerant R404A, enter the following data on page 28:

- pressure drop across the valve = 9.73 bar
- evaporation temperature = - 5°C
- calculated evaporator potential = 2.91 kW

to select the corresponding orifice 04 (N.B. the valve potential must be equal to or slightly greater than the calculated evaporator potential)

VALVE SIZING EXAMPLE

Abbreviation	Description	Value	UM	NOTES
R	Type of refrigerant	R404A		
Qe	Evaporator potential	2.8	kW	
Te/Pe	Evaporation temperature/pressure	-5.0000	°C	
Tc/Pc	Minimum condensation Temperature/ Pressure	37.0000	°C	
TI	Liquid refrigerant temperature, at the valve inlet	20.0000	°C	If it is not indicated, a value will be assumed so as to determine sub- cooling of 4 °C
ΔP	Pressure drop - loss	2.0000	bar	If it is not indicated, a value of 2 bar will be assumed
ODS	Connection size	mm	mm	
V	Coil power supply	220/230 Vac	V	
f	Coil frequency	50	Hz	

SELECTED VALVE	PXVBM10S04100
SELECTED COIL	PXVB0ARA60100

CALCULATED VALUES			
$\Delta P_{tot} = P_c - (P_e + \Delta P)$	Pressure drop across the valve	9.73	bar
		129.30	PSI
$\Delta t_{sub} = T_c - T_I$	Sub-cooling temperature	17.0	°C
		62.6	°F
$Q_{sub} = F_{sub} \times Q_e$	Evaporator potential correction based on sub-cooling	2.324	kW
$Q_{ev} = Q_{sub} \times F_{ev}$	Evaporator potential correction based on application	2.905	kW

Eliwell Controls s.r.l.
Via dell'Industria, 15 • Zona Industriale Paludi •
32016 Alpago (BL) ITALY
T +39 0437 986 111
T +39 0437 986 100 (Italy)
+39 0437 986 200 (other countries)
E saleseliwell@se.com
Technical helpline +39 0437 986 300
E techsuppeliwell@se.com
www.eliwell.com

MADE IN ITALY

code 9MA10290.02 • EEV PXV • rel.06/21 • EN
© 2021 Eliwell • All rights reserved